

Design Features

Housing: Heavy gauge cast aluminum housing is designed for recessed dry or concrete pour applications. Splice box is provided with two wire entry holes. Specify either 1/2" or 3/4" NPT. Neoprene gasket is installed between housing and face-plate.

Face-Plate: Rugged cast aluminum face-plate with vertical louvers over clear glass lens. Face-plate is secured to housing with two recessed stainless steel tamperproof fasteners.

Optical System: Diffused satin aluminum reflector provides asymmetric distribution.

Ballast/Lamp Assembly: HID ballast shall have a high power factor. Fluorescent ballast shall be electronic dual voltage. HID sockets shall be porcelain, medium base and pulse-rated.

Finish: Polyester powder coating on all metal parts. Color to be specified.

Listing: Luminaire is ETL listed for wet locations.

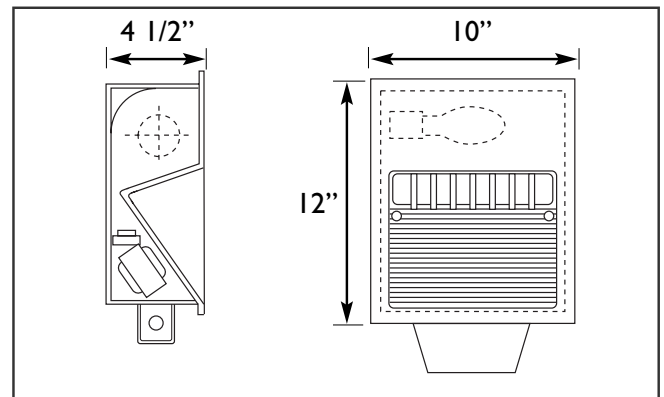

Specification Guide

Series	Wattage/Lamp	Volts	Options	Finish
CW	26w/PLQ = I26P	120	IF = Single Fuse	BZ = Bronze
	32w/PLT = I32P	208	2F = Double Fuse	BK = Black
	42w/PLT = I42P	240	QR = Quartz Relay	WH = White
	50w/MH = I05H	277		SL = Silver
	70w/MH = I07H			CC = Custom Color
	70w/HPS = I07S			
	50w/HPS = I05S			

Example: 50 Watt, High Pressure Sodium, 120 Volts, Single Fuse, Black
CW-I05S-120/IF/BK