

# ST 100 Series



## Design Features

**Housing:** Three heavy gauge (.188) extruded aluminum sections are welded to cast aluminum end caps to form lamp housing.

**Lens Assembly:** Extruded aluminum door frame houses 3/16" clear tempered glass. Gasketed frame is secured to housing with stainless steel tamper resistant fasteners.

**Optical System:** Satin anodized reflector is provided to help distribute the light in a smooth asymmetric distribution.

**Ballast/Lamp Assembly:** All ballast shall be high power factor and be suitable for -20° F operation. The ballast module is easily removable for maintenance. Lamp sockets shall be porcelain medium base pulse-rated.

**Mounting Bracket:** Heavy gauge yoke bracket secures lamp housing with two flat head screws, which allows vertical aiming. Bracket is secured to wall with (4) bolts provided by contractor.

**Finish:** Polyester powder coating on all metal parts. Color to be specified.

**Listing:** Luminaire is ETL listed.

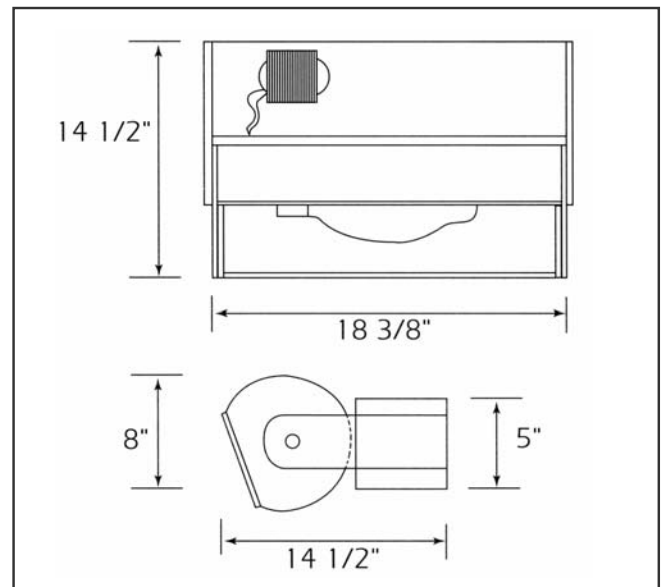
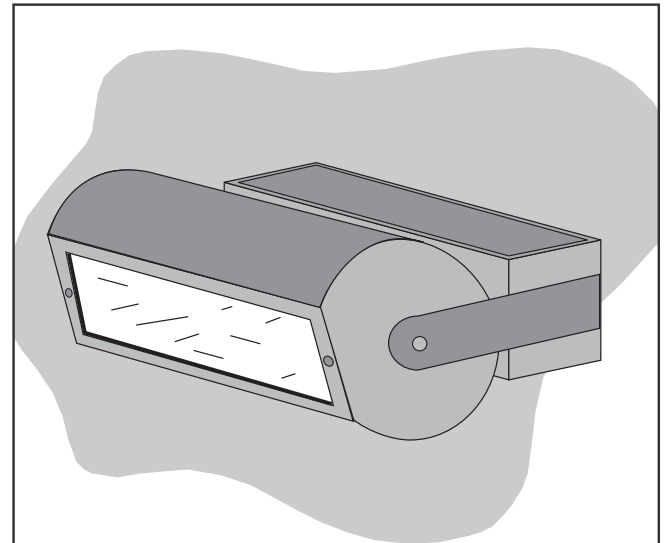

## Specification Guide

Series	Wattage/Lamp	Volts	Options	Finish
ST-I	70w/HPS = 07S	120	IF = Single Fuse 2F = Double Fuse QR = Quartz Relay	BZ = Bronze BK = Black WH = White SL = Silver CC = Custom Color
	100w/HPS = 10S	208		
	150w/HPS = 15S	240		
	70w/MH = 07H	277		
	100w/MH = 10H	480		
	175w/MH = 17H			

**Example:** 100 Watt, Metal Halide, 120 Volts, Single Fuse, Bronze  
ST-I10H-120/IF/BZ