

## Design Features

**Housing:** Heavy gauge aluminum housing is internally welded and sealed to prevent water entry or light leaks. Lens frame support is welded to housing and sealed. Two weep holes are in back of housing to allow water run off when used in wet locations. If luminaire is to be mounted up specify with "UM".

**Lens Frame:** Formed from extruded aluminum, the frame rests on the raised support frame in housing. This allows water to travel between lens frame and support frame and out the weep holes. Lens frame is gasketed and secured with two stainless steel tamper-proof fasteners.

**Lens:** A clear heat tempered glass lens is secured in frame with (4) clips.

**Optical System:** Segmented reflector assembly combines specular and hammertone aluminum to produce a smooth forward throw distribution. Optional wide side to side throw is available. "WT"

**Ballast/Lamp Assembly:** All HID ballast shall have a high power factor and be suitable for -20° F operation. The ballast module is easily removable for maintenance. The lamp socket shall be porcelain medium base pulse-rated.

**Mounting Bracket:** Housing bolts directly to wall. Unit should be sealed at wall when used outdoors.

**Finish:** Polyester powder coating on all metal parts. Color to be specified.

**Listing:** Luminaire is ETL listed for wet locations.

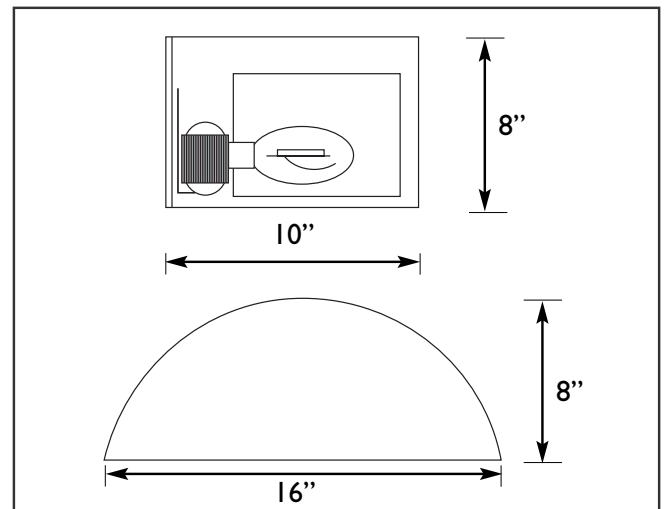
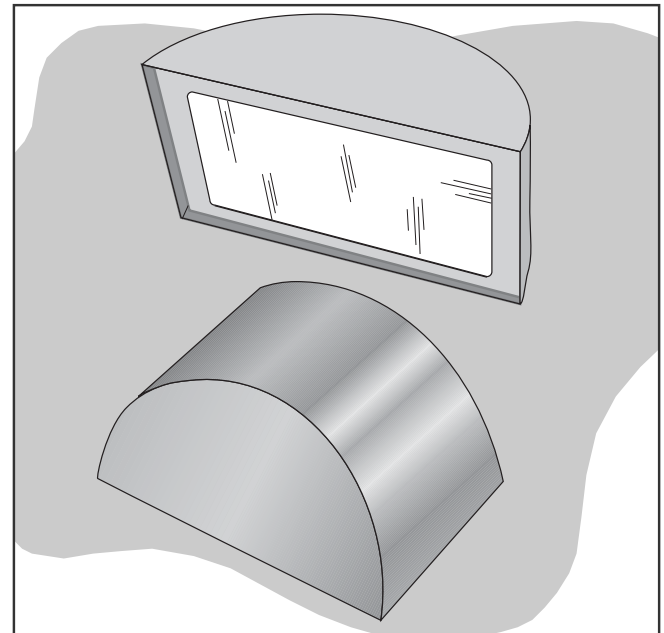

## Specification Guide

Series	Wattage/Lamp	Volts	Options	Finish
SR-I	70w/HPS = 07S	120	1F = Single Fuse	BZ = Bronze
	100w/HPS = 10S	208	2F = Double Fuse	BK = Black
	150w/HPS = 15S	240	PH = Button Cell	WH = White
	70w/MH = 07H	277	QR = Quartz Relay	SL = Silver
	100w/MH = 10H	480	UM = Up Mounted	CC = Custom Color
	175w/MH = 17H		WT = Wide Throw	

**Example:** 100 Watt, Metal Halide, 120 Volts, Single Fuse, Bronze  
**SR-I 10H-120/1F/BZ**