

YSW-2-800 Series



Design Features

Housing: Aluminum body with lensed top and bottom is attached to the back pan, which contains ballast and socket assembly with flush mounted stainless steel screws.

Lens Assembly: Clear tempered glass lens is secured in the aluminum frame with four clips. Gasket is installed between the glass and the frame and between frame and housing. The assembly is secured to the housing with four flush stainless steel fasteners.

Optical System: Spun aluminum reflectors with specular finish are attached to frames. Reflectors provide a smooth symmetrical distribution.

Mounting Bracket: Extruded aluminum arm is internally welded to cast back plate. Arm is bolted to housing with two 3/8" bolts. Steel zinc plated bracket mounts to wall surface and is attached to the cast plate with two stainless steel fasteners.

Ballast/Lamp Assembly: All ballast shall have a high power factor and be suitable for -20° F operation. The ballast module is easily removable for maintenance. The lamp socket shall be porcelain medium base pulse-rated and securely mounted to housing.

Finish: Polyester powder coating on all metal parts. Color to be specified.

Listing: Luminaire is ETL listed for wet locations.

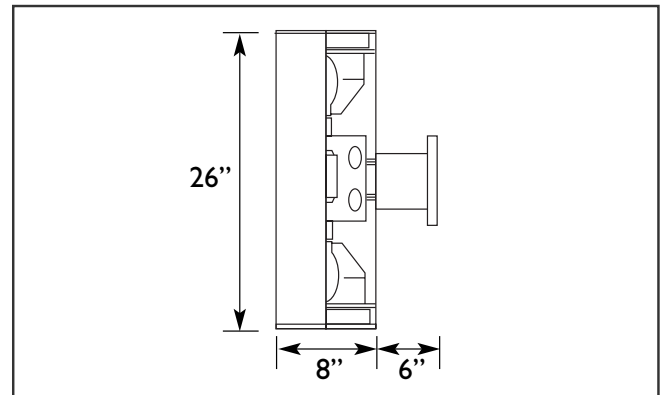
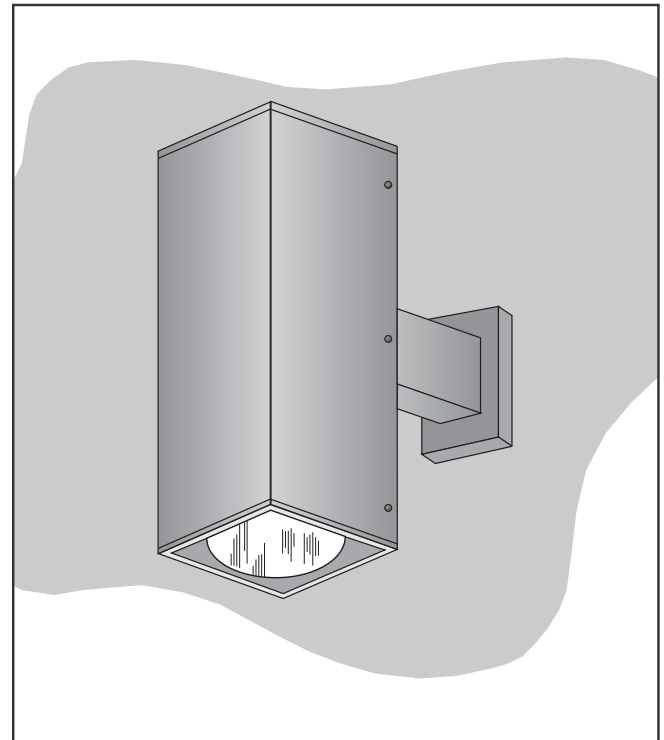

Specification Guide

Series	Wattage/Lamp	Volts	Options	Finish
YSW-2	100w/MV = 810V	120	1F = Single Fuse	BZ = Bronze
	70w/HPS = 807S	208	2F = Double Fuse	BK = Black
	100w/HPS = 810S	240	PH = Button Cell	WH = White
	150w/HPS = 815S	277	FL = Fresnel Lens	SL = Silver
	70w/MH = 807H	480		CC = Custom Color
	100w/MH = 810H			

Example: 100 Watt, Metal Halide, 120 Volts, Single Fuse, Bronze
YSW-2-810H-120/1F/BZ