

Design Features

Housing: Four heavy gauge .188 wall extruded aluminum sections interlock to form the cylinder housing. Two sections are internally welded to lower cast lens frame and two sections are bolted to mounting bracket and welded to upper lens frame.

Lens Assembly: Clear heat tempered glass lens are sealed in regressed cast aluminum frames. The lower frame is welded to two extruded sections which easily slides down for relamping and ballast maintenance by releasing a single set screw. A safety chain secures the frame in place.

Optical System: Spun aluminum reflectors with specular finish are attached to cast frame. Reflectors provide a smooth symmetrical distribution.

Mounting Bracket: Extruded aluminum arm is internally welded to cast back plate. Arm is bolted to housing with two 3/8" bolts. Steel zinc plated bracket mounts to wall surface and is attached to the cast plate with two stainless steel fasteners.

Ballast/Lamp Assembly: All ballast shall have a high power factor and be suitable for -20° F operation. The ballast module is easily removable for maintenance. The lamp socket shall be porcelain medium base pulse-rated and securely mounted to housing.

Finish: Polyester powder coating on all metal parts. Color to be specified.

Listing: Luminaire is ETL listed for wet locations.

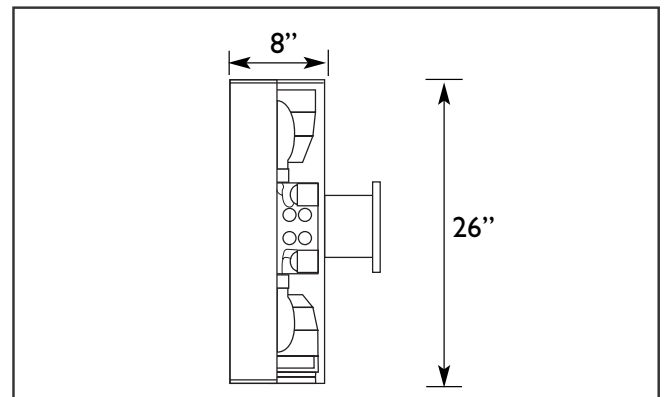
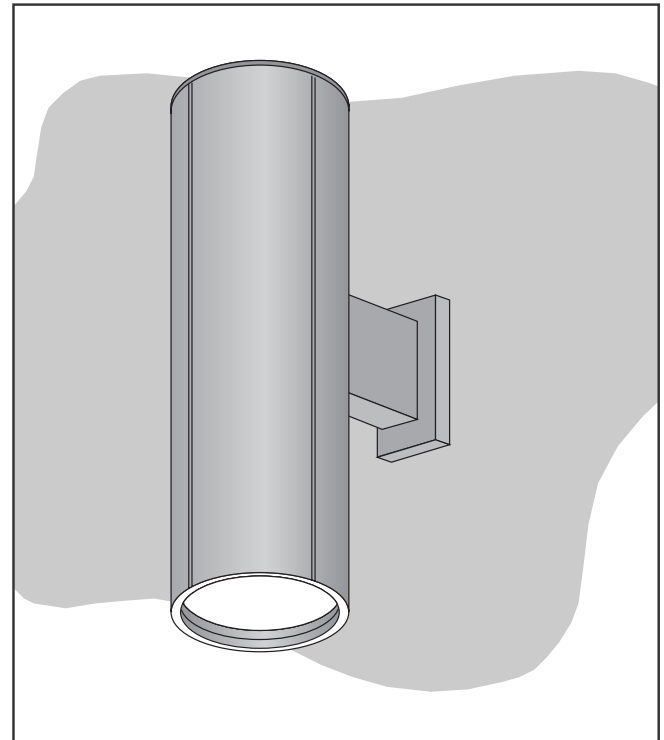

Specification Guide

Series	Wattage/Lamp	Volts	Options	Finish
YRW-2	100w/MV = 810V	120	1F = Single Fuse	BZ = Bronze
	70w/HPS = 807S	208	2F = Double Fuse	BK = Black
	100w/HPS = 810S	240	PH = Button Cell	WH = White
	70w/MH = 807H	277	FL = Fresnel Lens	SL = Silver
	100w/MH = 810H	480		CC = Custom Color

Example: 100 Watt, Metal Halide, 120 Volts, Single Fuse, Bronze
YRW-2-810H-120/1F/BZ