

YRP 1200 Series



Design Features

Housing: Four heavy gauge extruded aluminum sections interlock to form the cylinder. Ballast support brackets with 1/4" threaded studs are internally welded to the housing. Cast top with heat fins is welded to housing and threaded for 1/2" pendant.

Lens Assembly: Clear tempered glass lens is secured in regressed cast aluminum frame with three clips. Gasket is installed between the glass and the frame and between frame and housing. Frame is secured to the housing with three flush stainless steel fasteners.

Optical System: Spun aluminum reflector with specular finish is attached to cast frame. Reflector provides a smooth symmetrical distribution.

Pendant Assembly: Extruded aluminum pendant is threaded for secure fit to housing cap. It is provided with a swivel canopy and universal bracket for mounting to J-Box. Pendant length must be specified when ordering.

Ballast/Lamp Assembly: All ballast shall have a high power factor and be suitable for -20° F operation. The ballast module is easily removable for maintenance. The lamp socket shall be porcelain medium base pulse-rated for 175 watt and mogul base for 250 watt units.

Finish: Polyester powder coating on all metal parts. Color to be specified.

Listing: Luminaire is ETL listed for wet locations.

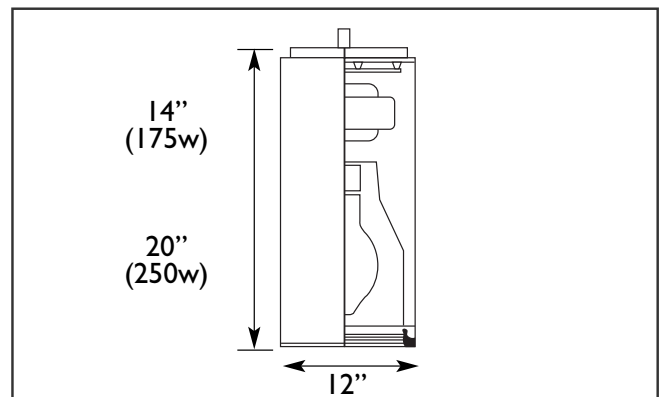
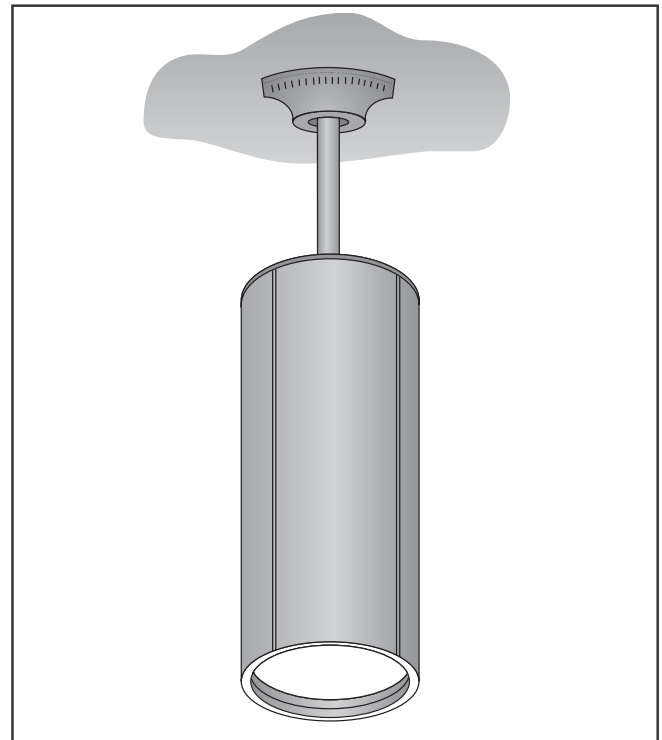

Specification Guide

Series	Wattage/Lamp	Volts	Pendant	Options	Finish
YRP	70w/HPS = 1207S	120	12"	1F = Single Fuse	BZ = Bronze
	100w/HPS = 1210S	208	24"	2F = Double Fuse	BK = Black
	150w/HPS = 1215S	240	30"	PH = Button Cell	WH = White
	250w/HPS = 1225S	277	36"	FL = Fresnel Lens	SL = Silver
	70w/MH = 1207H	480	Other	PSB = Pulse Start Ballast	CC = Custom Color
	100w/MH = 1210H				
	175w/MH = 1217H				
	250w/MH = 1225H				

Example: 100 Watt, Metal Halide, 120 Volts, 12" Pendant, Single Fuse, Bronze
YRP-1210H-120/12"/1F/BZ