

YRD 800 Series



Design Features

Housing: Four heavy gauge .188 wall extruded aluminum sections interlock to form the cylinder housing. Two sections are internally welded to the cast lens frame and two sections which are bolted to mounting bracket have the dome top welded to it.

Dome Cap: Heavy gauge .125 wall hydroformed hemispherical cap is welded to one section of extruded housing.

Lens Assembly: Clear heat tempered glass lens is sealed in regressed cast aluminum frame. The frame is welded to two extruded sections which easily slides down for relamping and ballast maintenance by releasing a single set screw. A safety chain secures the frame in place.

Optical System: Spun aluminum reflector with specular finish is attached to cast frame. Reflector provides a smooth symmetrical distribution.

Mounting Bracket: Extruded aluminum arm is internally welded to the cast back plate. Arm is bolted to housing with two 3/8" bolts. Steel zinc plated bracket mounts to wall surface and is attached to the cast plate with two stainless steel fasteners.

Ballast/Lamp Assembly: All ballast shall have high power factor and be suitable for -20° F operation. The ballast module is easily removable for maintenance. The lamp socket shall be porcelain medium base pulse-rated and securely mounted to housing.

Finish: Polyester powder coating on all metal parts. Color to be specified.

Listing: Luminaire is ETL listed for wet locations.

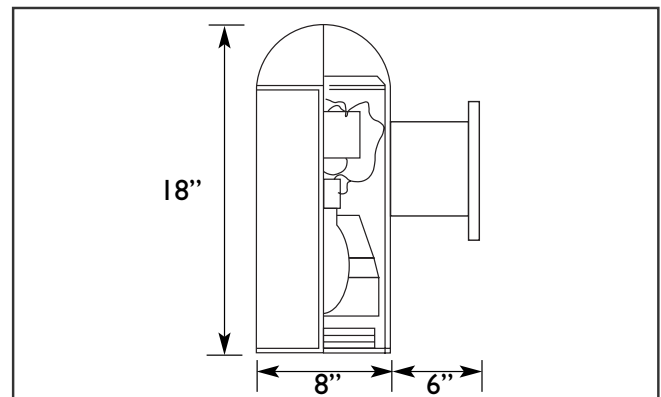
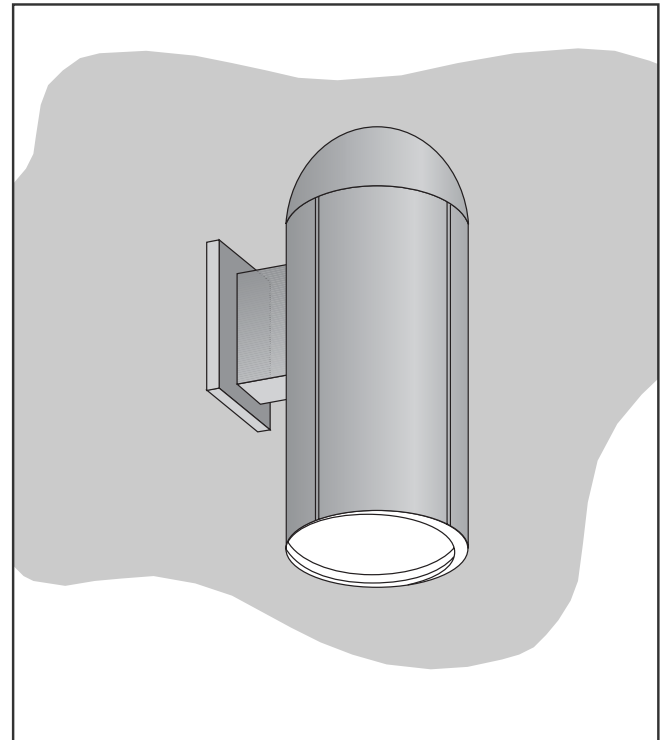

Specification Guide

Series	Wattage/Lamp	Volts	Options	Finish
YRD	100w/MV = 810V	120	1F = Single Fuse	BZ = Bronze
	70w/HPS = 807S	208	2F = Double Fuse	BK = Black
	100w/HPS = 810S	240	PH = Button Cell	WH = White
	150w/HPS = 815S	277	FL = Fresnel Lens	SL = Silver
	70w/MH = 807H	480	PSB = Pulse Start Ballast	CC = Custom Color
	100w/MH = 810H		PDM = Pendant Mount	
	175w/MH = 817H			

Example: 100 Watt, Metal Halide, 120 Volts, Single Fuse, Bronze
YRD-810H-120/1F/BZ