

## Design Features

**Housing:** Heavy gauge spun aluminum shroud is secured to the cast dome top with three stainless steel fasteners. The tenon on the dome slips inside the arm bracket and is secured with stainless steel fasteners.

**Lens Assembly:** Tempered clear glass is attached to the spun aluminum frame with four retaining clips. Frame is gasketed and secured to housing with three fasteners and two aircraft cables.

**Reflector:** Segmented reflector produces a Type 4 distribution. A hydroformed reflector is supplied for Type 2 and 3 distributions.

**Bracket Assembly:** Extruded aluminum arm with 12" radius bend slips over a 3.5" diameter pole tenon and is secured with six stainless steel fasteners.

**Ballast/Lamp Assembly:** All ballast shall have a high power factor and be suitable for -20° F operation. The ballast module is secured inside the dome cap and supplied with quick disconnects. Sockets shall be porcelain, mogul base and pulse-rated.

**Finish:** Polyester powder coating on all metal parts. Color to be specified.

**Listing:** Luminaire is ETL listed for wet locations, UL 1598 and Canadian CSA Std. C22.2 No. 250.0.

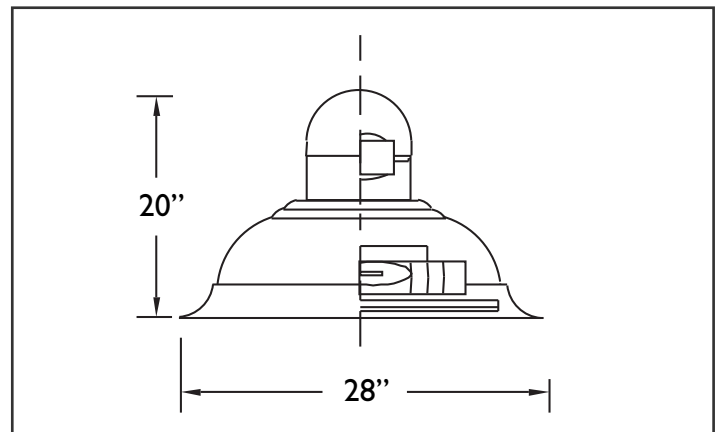
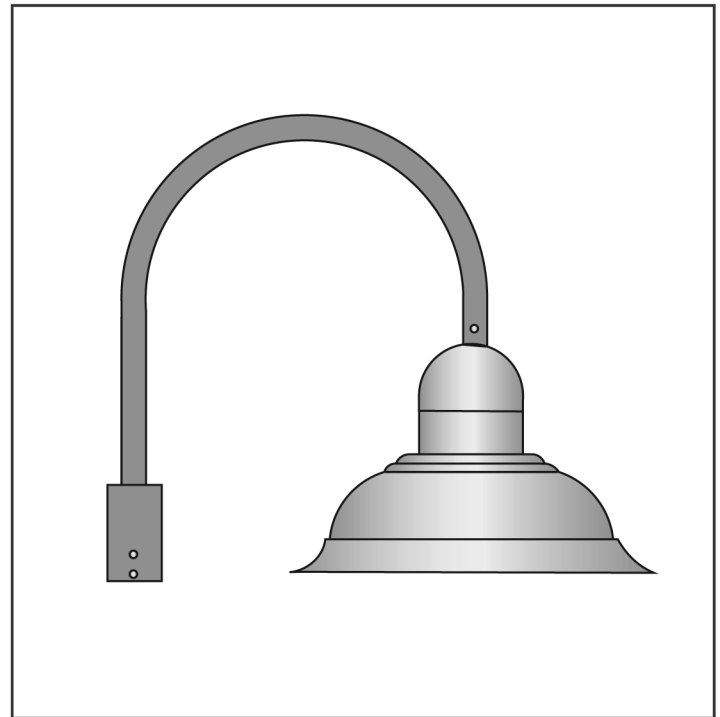

## Specification Guide

Series	Wattage/Lamp	Volts	Options	Finish
VK-31	175w/MH = 17H	120	1F = Single Fuse	BZ = Bronze
	250w/MH = 25H	208	2F = Double Fuse	BK = Black
	400w/MH = 40H	240	PH = Button Cell	WH = White
	150w/HPS = 15S	277	2A = Twin @ 180	SL = Silver
	250w/HPS = 25S	480	R2 = Type 2 Distribution	CC = Custom Color
	400w/HPS = 40S		R3 = Type 3 Distribution	
			R4 = Type 4 Distribution	
			PSB = Pulse Start Ballast	

**Example:** 400 Watt, Metal Halide, 120 Volts, Type 3 Distribution, Single Fuse, Black  
**VK-3140H-120/R3/1F/BZ**