

Design Features

Housing: The spun aluminum shroud is supplied with a 1/2" threaded coupling for attachment to the arm bracket.

Enclosure: Clear tempered glass lens threads into cast aluminum adapter, which is mounted to the shroud. Cast aluminum guard is available upon request.

Ballast Assembly: Extruded aluminum arm threads into the housing and is welded to the cast aluminum ballast box cover plate. Optional with 1/2" pendant and swivel canopy "PDM."

Ballast/Socket: High power factor ballast and pulse-rated medium base sockets are supplied with HID sources. Electronic ballast with 4-pin socket is supplied for compact fluorescent lamp.

Ballast Compartment: Ballast mounts in the cast aluminum box with two fasteners. A steel zinc plated bracket bolts to the j-box or directly to the wall. The cast ballast compartment bolts to the steel plate with three stainless steel fasteners.

Finish: Polyester powder coating on all metal parts. Color to be specified.

Listing: Luminaire is ETL listed for wet locations, UL 1598 and Canadian CSA Std. C22.2 No 250.0.

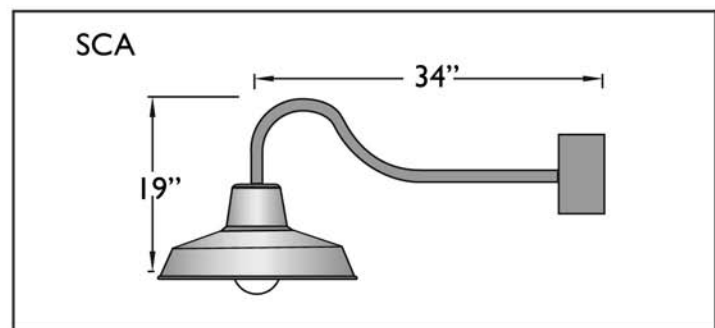
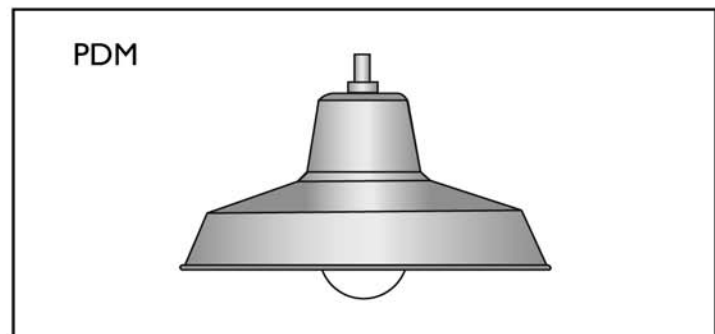
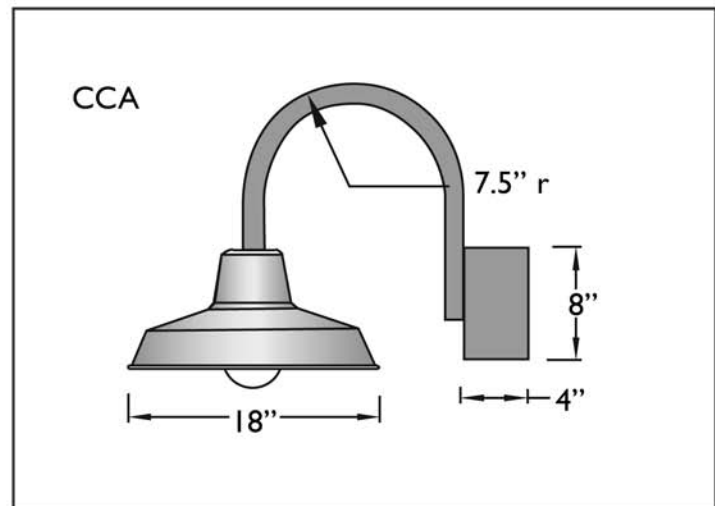

Specification Guide

Series	Wattage/Lamp	Volts	Options	Finish
RLM-18	70w/MH = 07H	120	CG = Cast Guard	BZ = Bronze
	100w/MH = 10H	208	PG = Prismatic Glass	BK = Black
	26w/PLQ = 26P	240	FG = Frosted Glass	WH = White
	32w/PLQ = 32P	277	CCA = Candy Cane Arm	SL = Silver
	42w/PLQ = 42P		SCA = Shepherd Crook	CC = Custom Color
	200w/INC = 20I		PDM = Pendant Mount	

Example: 100 Watt, Metal Halide, 120 Volts, Single Fuse, Bronze
RLM1810H-120/1F/BZ